

**NOTES:**

- THE GMT232 (M22520/37-01) CRIMP TOOL IS DESIGNED TO TERMINATE WIRE SPLICE CONFORMING TO MIL-S-81824 OF THE FOLLOWING SIZES:

TOOL CAVITY	12-16		16-20		20-26	
CRIMP SPLICE SIZE	I.D.	O.D.	I.D.	O.D.	I.D.	O.D.
	.102	.153	.069	.106	.050	.080
	.097	.147	.064	.101	.045	.075

- A PROPERLY CALIBRATED GMT232 (M22520/37-01) CRIMP TOOL HAS THE FOLLOWING CHARACTERISTICS:

- RATCHET ADJUSTMENT (SET AT THE FACTORY): A COMPRESSION FORCE 40 POUNDS MIN. APPLIED 1.50±.12 INCHES FROM THE END OF THE HANDLES SHALL BE REQUIRED TO COMPLETELY CLOSE JAWS BEFORE THE RATCHET MECHANISM RELEASES THE HANDLES.
- JAW CLOSING: WITH THE JAWS FULLY CLOSED, A "GO" GAGE SHALL FIT IN THE SPACE BETWEEN THE INDENTER AND ITS CORRESPONDING CAVITY. A "NO-GO" GAGE SHALL NOT FIT IN THIS SPACE. GAGE SIZES ARE AS FOLLOWS:

TOOL CAVITY	"GO" DIA.	"NO-GO" DIA.
12-16	.062	.072
16-20	.042	.052
20-26	.025	.035

THE DANIELS G411 (M22520/39-01) CRIMP TOOL GAGE IS RECOMMENDED FOR THIS PURPOSE.

- RATCHET IS SECURED TO PREVENT UNAUTHORIZED ADJUSTMENT.
- TOOL IS NOT EQUIPPED WITH AN EARLY RELEASE MECHANISM.

REVISIONS				
REV. SYM.	E.C.O. NUMBER	DESCRIPTION	BY DATE	APP'D DATE
9		REMOVED MAX DIMS	ENF 4/2012	RRR 4/2012

**UNCONTROLLED DOCUMENT  
WILL NOT BE UPDATED**

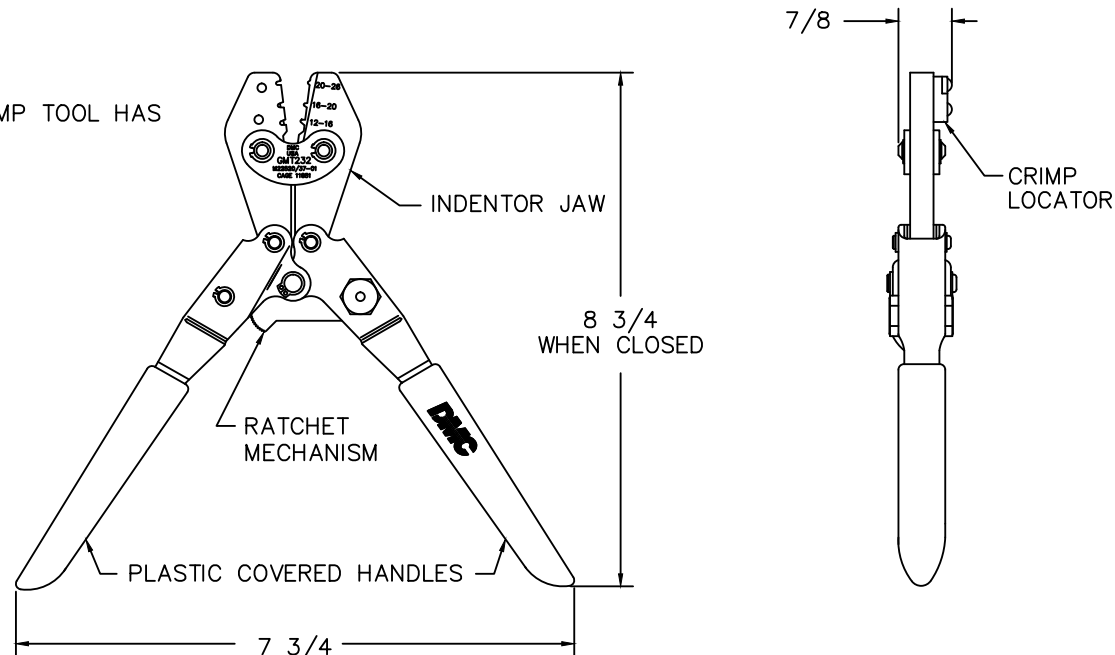

<b>RESTRICTED &amp; CONFIDENTIAL</b> <small>CONFIDENTIAL PROPERTY OF DANIELS MANUFACTURING CORP. NOT TO BE DISCLOSED TO OTHERS, REPRODUCED OR USED FOR ANY OTHER PURPOSE, EXCEPT AS AUTHORIZED IN WRITING BY DANIELS MANUFACTURING. MUST BE RETURNED TO DANIELS MANUFACTURING CORP. ON COMPLETION OF ORDER OR OTHER PURPOSE FOR WHICH LENT.</small>	MATERIAL	ITEM	PART NO.	QTY.	DESCRIPTION/REMARKS		
	HEAT TREAT	DRN.	DUNG CAO	DATE	<b>DMC</b> DANIELS MANUFACTURING CORP. ORLANDO, FLORIDA CAGE 11851		
		CHK'D.	DE	DATE			
	FINISH	APP'D.		DATE	TITLE CRIMP TOOL ENVELOPE DRAWING M22520/37-01		
APP'D.			DATE				
<b>DO NOT SCALE DRAWING</b>		<small>NOTE: THIS DRAWING IS AN OUTLINE DRAWING OF THE RESPECTIVE DMC PART NUMBER INDICATED. ACTUAL DMC PART NUMBER IS DRAWING NUMBER WITHOUT THE "-ENV" SUFFIX.</small>		WHERE USED:			
				SIZE	SCALE	CAD P/N	SHEET OF
				B	NTS	GMT232-ENV	1 1
				POSTING	DWG. NO.	REV.	
		GMT232-ENV	9				