

USERS MUST ASSURE THEY ARE USING THE CORRECT REVISION.

REVISIONS

REV	ECO NO.	DESCRIPTION	BY	DATE	APP'D BY	DATE
1		ORIGINAL RELEASE	DUNG CAO	9/25/1995	DE	9/25/1995
2		REDRAWN ; ADDED GAGE NOTES ; ADDED .463	K. KOONS	4/13/2018		

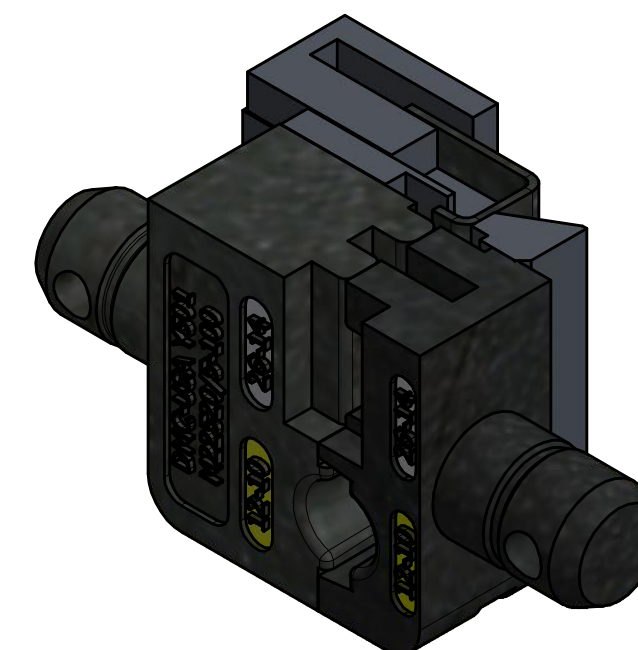
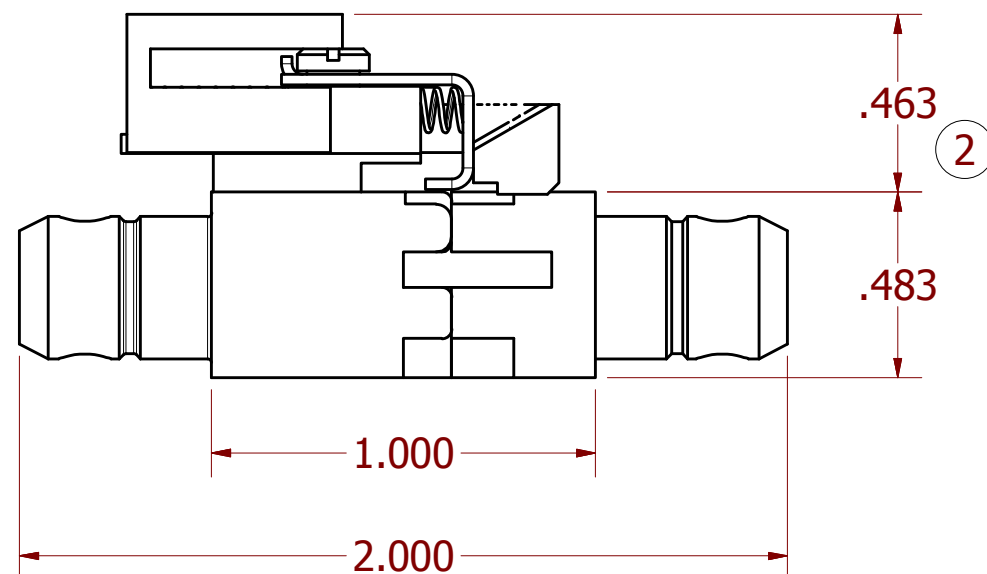

ISOMETRIC VIEW  
REF ONLY

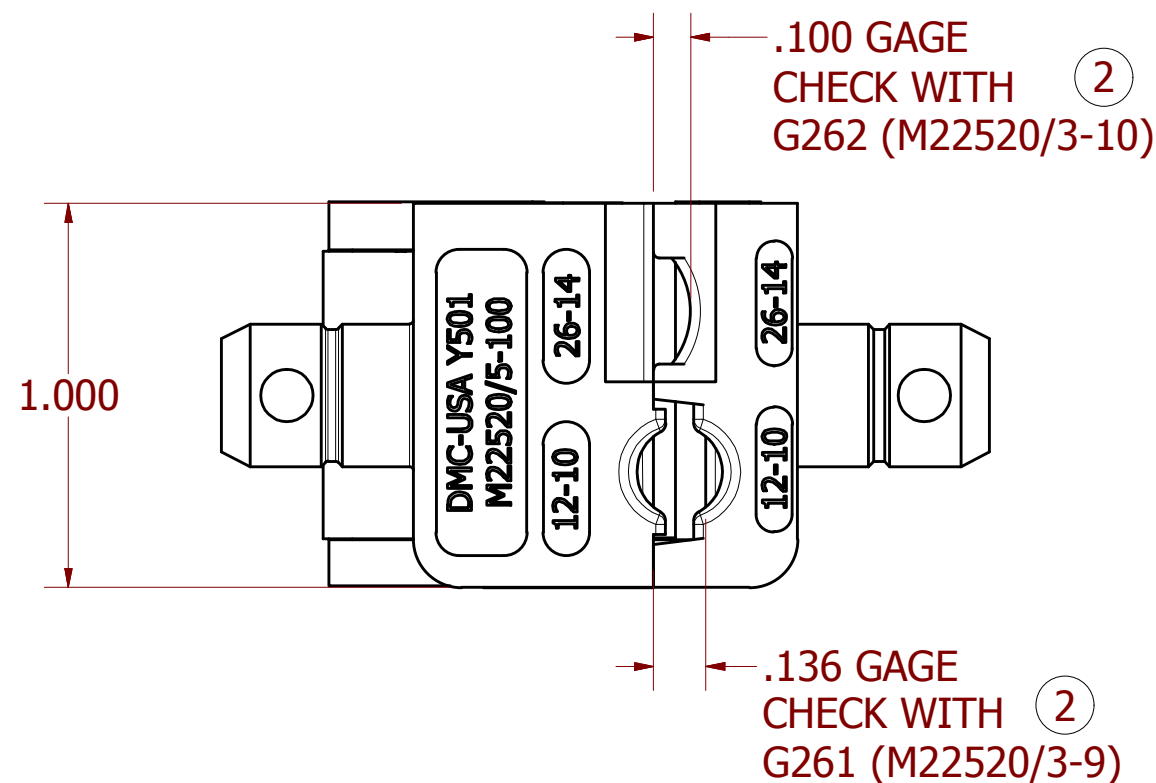

**UNCONTROLLED DOCUMENT  
WILL NOT BE UPDATED**

DIMENSIONS IN INCHES - UNLESS OTHERWISE SPECIFIED

NOTES:

RESTRICTED & CONFIDENTIAL  
CONFIDENTIAL PROPERTY OF DANIELS MANUFACTURING CORP. NOT TO BE DISCLOSED TO OTHERS. REPRODUCTION OR USED FOR ANY OTHER PURPOSE EXCEPT AS AUTHORIZED IN WRITING BY DANIELS MANUFACTURING. MUST BE RETURNED TO DANIELS MANUFACTURING CORP. ON COMPLETION OF ORDER OR PURPOSES FOR WHICH LENT.

CREATED FROM AN INVENTOR MODEL.  
CHANGES MUST BE REFLECTED IN THE 3D PART

DO NOT SCALE DRAWING

MATERIAL	ITEM	PART NO.	QTY.	DESCRIPTION / REMARKS
NA	DRN. KR CHK'D. JW	DATE 10/13/1984 DATE 10/15/1984		 DANIELS MANUFACTURING CORP. ORLANDO, FLORIDA CAGE 11851
HEAT TREAT	NA	NOTE: THIS DRAWING IS AN OUTLINE DRAWING OF THE RESPECTIVE DMC PART NUMBER INDICATED. ACTUAL DMC PART NUMBER IS CAD PART NUMBER WITHOUT THE "-ENV" SUFFIX		TITLE DIE SET (M22520/5-100) ENVELOPE DRAWING WHERE USED:
FINISH	NA			SIZE B SCALE 2 : 1 CAD P/N Y501-ENV SHEET 1 OF 1 DWG. NO. Y501 REV. 2